

## Basic Characteristics Data

Model	Circuit method	Switching frequency [kHz]	Input current [A]	Rated input fuse	Inrush current protection	PCB/Pattern			Series/Parallel operation availability	
						Material	Single sided	Double sided	Series operation	Parallel operation
DPF1000	Active filter	130	11.5 *1	-	SCR	Aluminum	Yes		No	Yes
			8.5 *2							

\*1 The value of input current is at ACIN 100V and 1000W load.

\*2 The value of input current is at ACIN 200V and 1500W load.

<b>1</b>	<b>Pin Connection</b>	H-92
<b>2</b>	<b>Input Voltage Derating</b>	H-92
<b>3</b>	<b>Standard Connection Method</b>	H-92
3.1	Standard connection method .....	H-92
3.2	External components .....	H-92
3.3	Wiring input pin .....	H-93
3.4	Connection of loaded circuit .....	H-93
3.5	Heatsink .....	H-93
<b>4</b>	<b>Function</b>	H-93
4.1	Overcurrent protection .....	H-93
4.2	Overvoltage protection .....	H-93
4.3	Thermal protection .....	H-93
4.4	Auxiliary power supply circuit for external signal(AUX) .....	H-93
4.5	Inverter operation monitor(IOG) .....	H-94
4.6	Enable signal(ENA) .....	H-94
4.7	Isolation .....	H-94
<b>5</b>	<b>Series and Parallel Operation</b>	H-94
5.1	Series operation .....	H-94
5.2	Parallel operation .....	H-94
5.3	N+1 redundant operation .....	H-95
<b>6</b>	<b>Implementation · Mounting Method</b>	H-95
6.1	Mounting method .....	H-95
6.2	Stress onto the pins .....	H-95
6.3	Cleaning .....	H-95
6.4	Soldering .....	H-95
6.5	Derating .....	H-96

# 1 Pin Connection

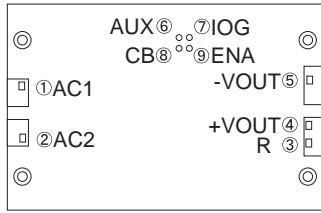

\* Bottom View

Table 1.1 Pin connection and function

No.	Pin connection	Function
①	AC1	AC Input
②	AC2	
③	R	External resistor for inrush current protection
④	+VOUT	+DC Output
⑤	-VOUT	-DC Output
⑥	AUX	Auxiliary power supply for external signal
⑦	IOG	Inverter operation monitor
⑧	CB	Current balance
⑨	ENA	Enable signal

No.	Reference
①	
②	3.3 "Wiring input pin"
③	3.2 "External components"
④	
⑤	3.4 "Connection of loaded circuit"
⑥	4.4 "Auxiliary power supply for external signal"
⑦	4.5 "Inverter operation monitor"
⑧	5.2 "Parallel operation"
⑨	4.6 "Enable signal"

# 2 Input Voltage Derating

Fig.2.1 shows rated output for each input voltage section.

Maximum output should be within this range.

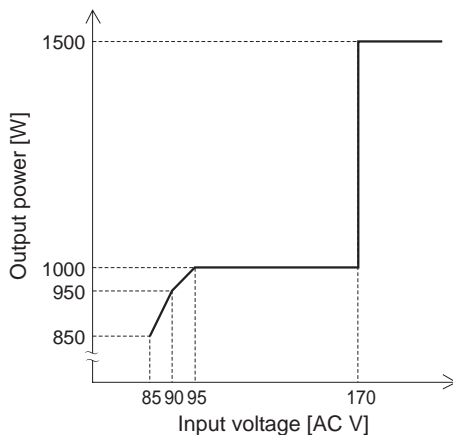

Fig.2.1 Input voltage derating curve

# 3 Standard Connection Method

## 3.1 Standard connection method

To use DPF1000, connection shown in Fig.3.1 and outside attached components are required. Through this connection, DC output voltage can be obtained from AC input voltage.

AC input voltage and DC output voltage are not insulated.

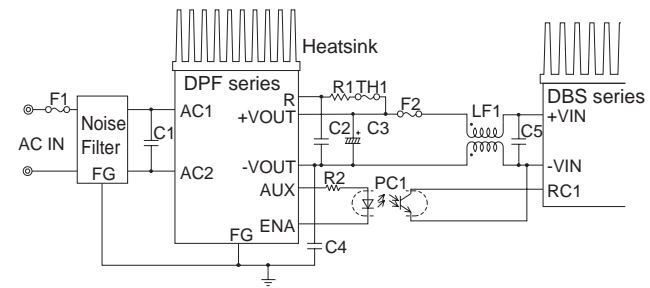

Fig.3.1 Standard connection method

Table 3.1 External components

No.	Symbol	Component	Required characteristics
①	F1	Input fuse	20A or less Slow-blow type
②	F2	Output fuse	10A or less Normal-blow type
③	C1	Input capacitor	2 $\mu$ F or more, Rated ripple current : 9A or more, Film capacitor, Safety approved type
④	C2	Output capacitor	1 $\mu$ F or more, Rated ripple current : 8A or more, Film capacitor
⑤	C3	Holdup capacitor	220 - 2200 $\mu$ F Aluminum electrolytic capacitor
⑥	C4	Y-capacitor	2200pF Safety approved type
⑦	R1	Inrush current protection resistor	4.7 - 10 $\Omega$ Wirewound Resistor with Thermal Cut-Offs

## 3.2 External components

F1 Input fuse : 20A or less

Fuse is not built-in at input side. In order to secure the safety, use the slow-blow type fuse F1 (20A or less).

F2 Output fuse : 10A or less

Since over current protection is not built-in, use the normal-blow type fuse F2 (10A or less) at output side to secure the safety.

C1 Input capacitor : 2 $\mu$ F or more

Install an external capacitor C1 (2 $\mu$ F or more) to keep stable operation and to avoid failure. Use AC250V rated voltage with safety approved and over 9A rated ripple current.

- C2 Output capacitor : 1 $\mu$ F or more  
Install an external capacitor C2 (1 $\mu$ F or more) as close as possible to the output pins to keep stable operation and to avoid failure. Use DC400V or higher rated voltage and over 8A rated ripple current capacitor.
- C3 Holdup capacitor : 220-2200 $\mu$ F  
Since holdup capacitor is not built-in, install electrolytic capacitor C3 (220 - 2200 $\mu$ F) close to the output pins. The rated ripple current of C3 and the holdup time for module should be considered. The capacitor value should be within 220 to 2200 $\mu$ F to avoid failure.
- C4 Y-capacitor : 2200pF  
Install an external capacitor C4 (2200pF) to keep stable operation. Use AC250V rated voltage with safety approved capacitor.
- R1 Inrush current protection resistor : 4.7 - 10 $\Omega$   
Connect a resistor between R pin and +Vout pin for inrush current protection. The surge capacity is required for R1, please contact component mfg. Wirewound resistor with thermal cut-offs type is required.

### 3.3 Wiring input pin

- A noise filter is not built in this power supply. Connect an external noise filter to reduce the conducted noise to the power supply line.
- A fuse to protect input is not built in. To assure safety, install a slow-blow fuse of 20A maximum to the input circuit F1.

### 3.4 Connection of loaded circuit

- For connecting the DBS/DAS series, see Fig.3.1.  
For details of F2, LF1 and C5, refer to the instruction manual for the DBS/DAS series.  
LF1 may not be required, depending on the noise standard or the design of the printed circuit board. In this case, ENA and RC1 can be directly connected, without having PC1.
- Control load current so that it may flow only when the terminal ENA is at "L". At "H" when inrush current protection circuit is not released, excessive current may be applied to the circuit.
- For connection of loads except the series DBS/DAS, please contact Cosel development department.

### 3.5 Heatsink

- The power supply adopts the conduction cooling system. Attach a heatsink to the aluminum base plate to cool the power supply for use. Refer to 6.5 Derating.

## 4 Function

### 4.1 Overcurrent protection

- The overcurrent protection circuit is not built-in.

### 4.2 Overvoltage protection

- The overvoltage protection circuit is built-in. The AC input should be shut down if overvoltage protection is in operation. The minimum interval of AC recycling for recovery is a few minutes which output voltage drops below 20V.

When this function operates, the power factor corrector function does not operate, and output voltage becomes the full-wave rectified AC input voltage.

#### Remarks:

Please note that the unit's internal components may be damaged if excessive voltage(over rated voltage) is applied to output terminal of power supply. This could happen when the customer tests the overvoltage performance of the unit.

### 4.3 Thermal protection

- Thermal protection circuit is built-in and it operates at 100 $\pm$ 15 $^{\circ}$ C. If this function comes into effect, shut down the output, eliminate all possible causes of overheating, and drop the temperature to normal level. To prevent the unit from overheating, avoid using the unit in a dusty, poorly ventilated environment.

When this function operates, the power factor corrector function does not operate, and output voltage becomes the full-wave rectified AC input voltage.

### 4.4 Auxiliary power supply circuit for external signal(AUX)

- The AUX pin can be used as the power source with the open collector output(output voltage DC 6.5 - 8.5V, maximum output current 10mA) for IOG and ENA.
- When used with AUX pin of additional units of this model for parallel connection, make sure to install a diode and that the maximum output current must be below 10mA.
- Never let a short circuit occur between the AUX pin and other pins. It may damage the unit.

### 4.5 Inverter operation monitor(IOG)

- Use IOG to monitor operation of the inverter.
 

When unit operation stopped due to overvoltage protection, thermal protection or the event of a failure in the power supply, IOG signal state changes to "H" from "L" within 1 second. And output voltage becomes an equal value to the full-wave rectified AC input voltage.

If IOG signal status keeps "H", there is a possibility that unit and/or external circuit is damaged. In case like this, please check the unit and/or external circuit conditions in your system.
- IOG can be used for monitoring failures such as redundant operation.
- IOG may become unstable in case of start-up or sudden change of load current. Set the timer with delay of more than 5 seconds.
- During parallel operation, unstable condition may occur when load current becomes lower than 10% of rated value.

### 4.6 Enable signal (ENA)

- Use ENA to control starting of the loaded power supply.
- When inrush current protection circuit is released, ENA outputs "LOW".
- If load current flows without releasing of the circuit, the resistor may be burnt.

Table 4.1 Specification of TMP, IOG

No.	Item	IOG	ENA
1	Function	Normal operation "L"	Output possible "L"
		Malfunction of inverter "H"	Output prohibited "H"
2	Base pin	-VOUT	
3	Level voltage "L"	0.6V max at 10mA	
4	Level voltage "H"	Open collector	
5	Maximum sink current	10mA max	
6	Maximum applied voltage	35V max	

### 4.7 Isolation

- For a receiving inspection, such as Hi-Pot test, gradually increase (decrease) the voltage for a start(shut down). Avoid using Hi-Pot tester with the timer because it may generate voltage a few times higher than the applied voltage, at ON/OFF of a timer.

## 5 Series and Parallel Operation

### 5.1 Series operation

- As input and output are not insulated, series operation is impossible.

### 5.2 Parallel operation

- Parallel operation is available by connecting the units as shown in Fig.5.1.
- As variance of output current drew from each power supply is maximum 10%, the total output current must not exceed the value determined by the following equation.

$$\begin{aligned} & \text{(Output current in parallel operation)} \\ & = (\text{the rated current per unit}) \times (\text{number of unit}) \times 0.9 \end{aligned}$$

In parallel operation, the maximum operative number of units is 5.

- When the output-line impedance is high, the power supply is become unstable. Use same length and thickness(width) wire(pattern) for the current balance improvement.
- Connect each input pin for the lowest possible impedance.
 

When the number of the units in parallel operation increases, input current increases. Adequate wiring design for input circuitry such as circuit pattern, wiring and current for equipment is required.
- If temperatures of aluminum base plates are different in the power supply for parallel operation, values of output current will change greatly
 

Design radiation to equalize plate temperatures by attaching the same heatsinks.
- Output diode Di is not required if capacity of output smoothing capacitor for parallel connection is below 2,500μF.

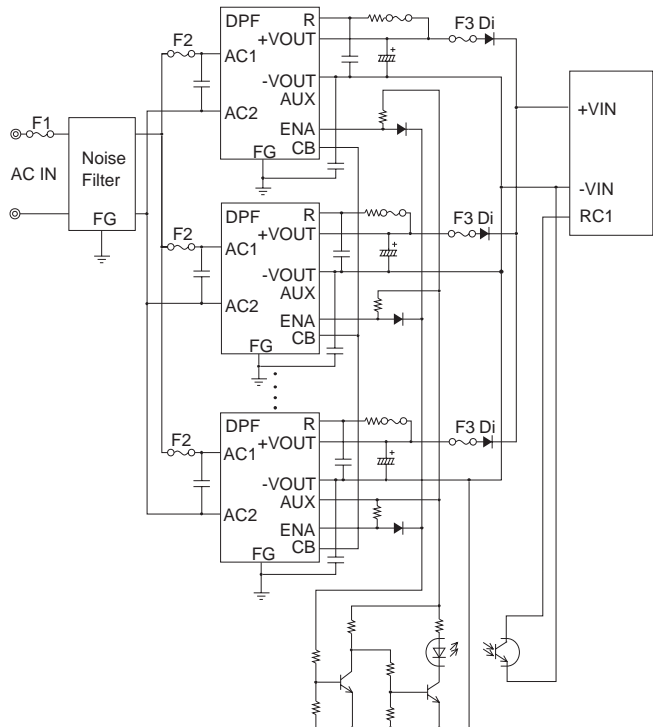

Fig.5.1 Parallel operation

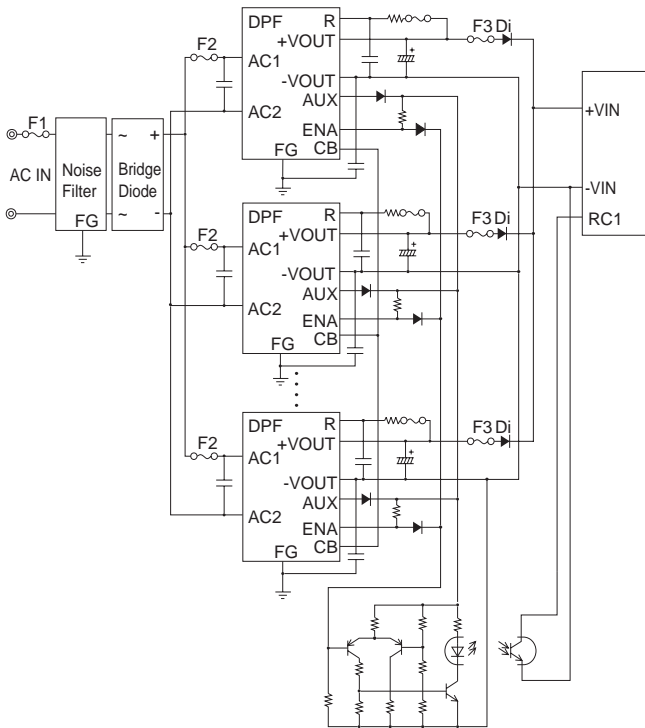

Fig.5.2 N+1 redundant operation

### 5.3 N+1 redundant operation

- It is possible to set N+1 redundant operation for improving reliability of power supply system. Connect as shown in Fig.5.2.
- Purpose of redundant operation is to ensure stable operation in the event of single power supply failure. Since extra power supply is reserved for the failure condition, so total power of redundant operation is equal to N.

## 6 Implementation - Mounting Method

### 6.1 Mounting method

- The unit can be mounted in any direction. When two or more power supplies are used side by side, position them with proper intervals to allow enough air ventilation. Aluminum base plate temperature around each power supply should not exceed the temperature range shown in derating curve.
- Avoid placing the AC input line pattern lay out underneath the unit, it will increase the line conducted noise. Make sure to leave an ample distance between the line pattern lay out and the unit. Also avoid placing the DC output line pattern of DC-DC converter underneath the unit because it may increase the output noise. Lay out the pattern away from the unit.

- High-frequency noise radiates directly from the unit to the atmosphere. Therefore, design the shield pattern on the printed circuit board and connect its one to FG. The shield pattern prevents noise radiation.

### 6.2 Stress onto the pins

- When too much stress is applied to the pins of the power supply, the internal connection may be weakened. As shown in Fig.6.1 avoid applying stress of more than 29.4N(3kgf) on the input pins/output pins(A part) and more than 9.8N(1kgf) to the signal pins(B part).
- The pins are soldered on PCB internally, therefore, do not pull or bend them with abnormal forces.
- Fix the unit on PCB(fixing fittings) to reduce the stress onto the pins.

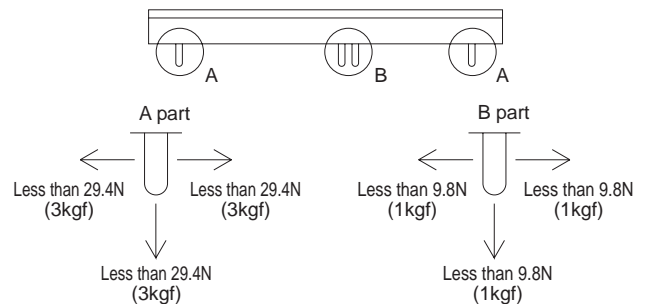

Fig.6.1 Stress onto the pins

### 6.3 Cleaning

- Clean the product with a brush. Prevent liquid from getting into the product. Do not soak the product into liquid.
- Do not stick solvent to a name plate or a resin case. (If solvent sticks to a name plate or a resin case, it will cause to change the color of the case or to fade letters on name plate away.)
- After cleaning, dry them enough.

### 6.4 Soldering

- Flow soldering : 260°C less than 15 seconds.
- Soldering iron
  - AC IN/DC OUT/R pins : 450°C less than 5 seconds.
  - Signal pins : 350°C less than 3 seconds(less than 20W).

### 6.5 Derating

■ Use with the conduction cooling (e.g. heat radiation by conduction from the aluminum base plate to the attached heat sink).

Fig.6.2 shows the derating curve based on the aluminum base plate temperature. In the hatched area, the specification of Ripple and Ripple Noise is different from other areas.

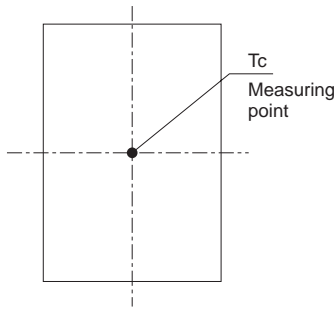
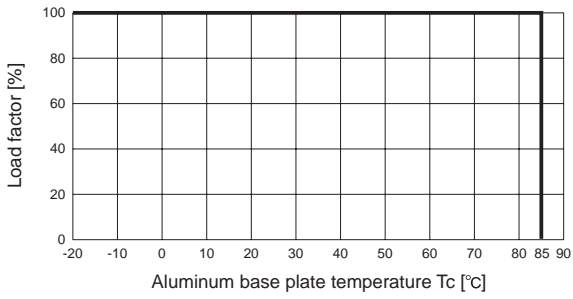

Fig.6.2 Derating curve