

CBS2004815 Derating with Heat Sink (H=0.25inch)

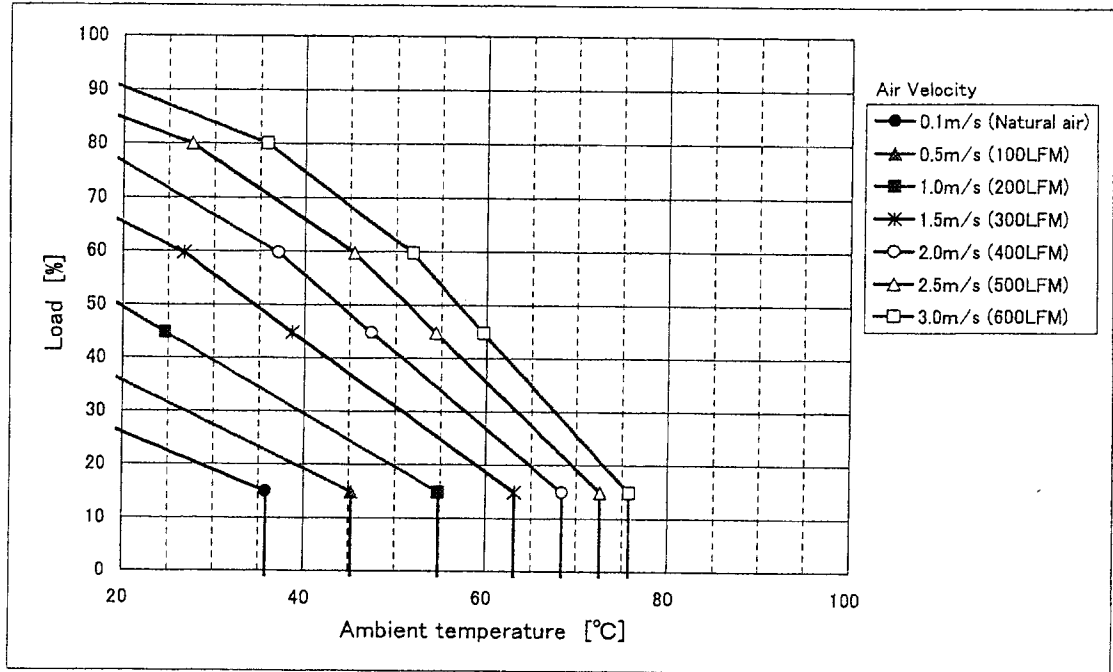

Fig. 1 CBS2004815 Derating (H=0.25inch)

※ 1 m/sec ≙ 200 LFM (linear feet per minute)

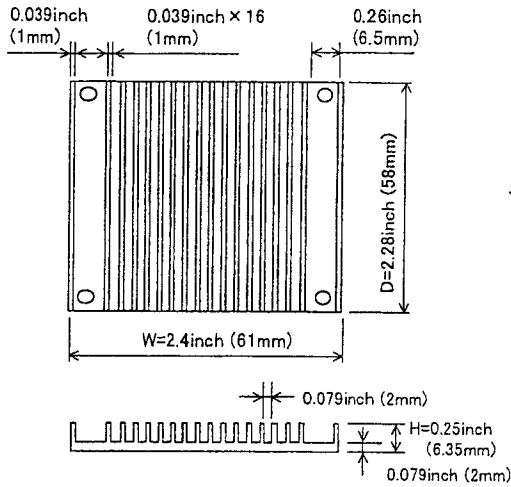

Fig.2 Size of Heat Sink

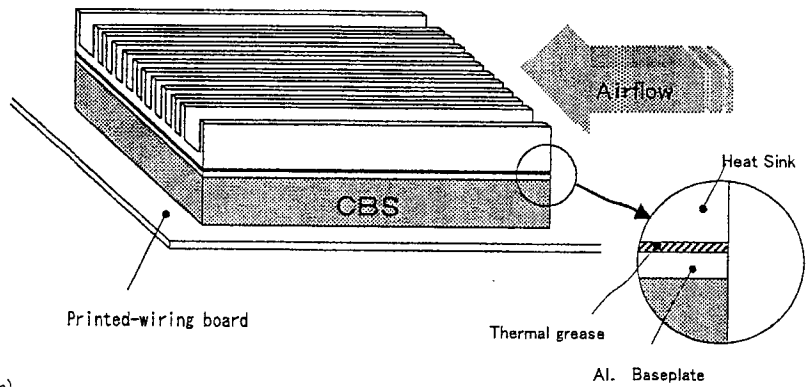

Fig.3 Test method

Note: Verify that baseplate temperature is below design level.

CBS2004815 Derating with Heat Sink (H=0.5inch)

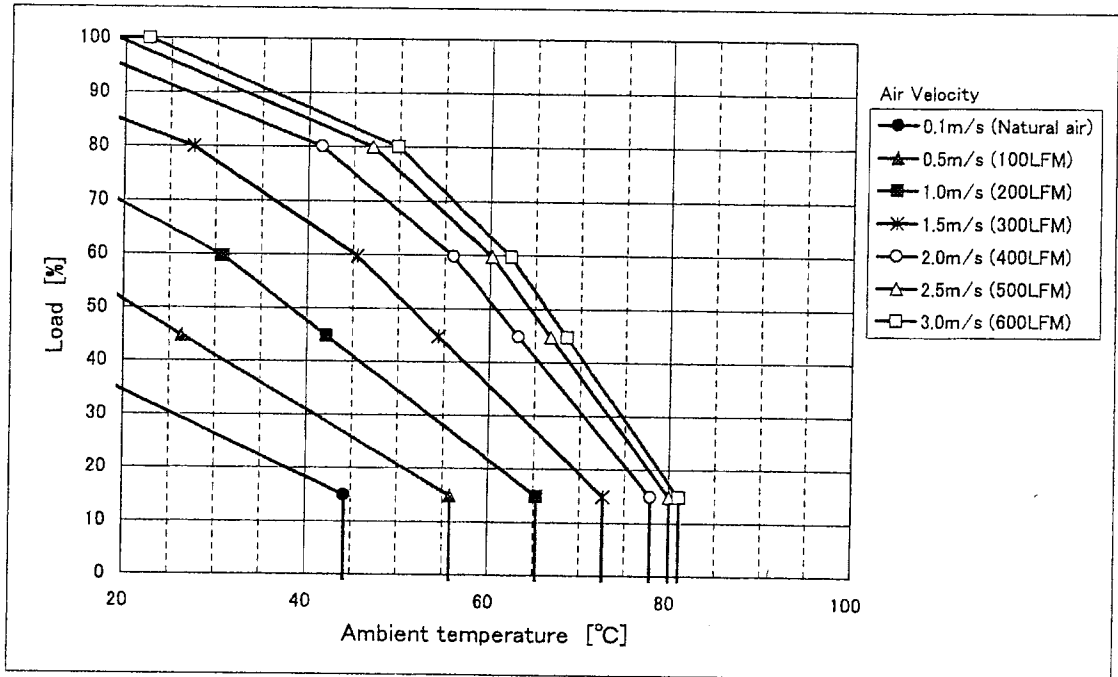

Fig. 1 CBS2004815 Derating (H=0.5 inch)

※ 1 m/sec ≅ 200 LFM (linear feet per minute)

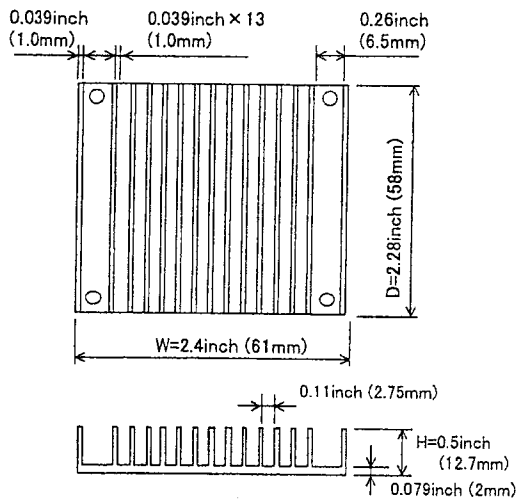

Fig.2 Size of Heat Sink

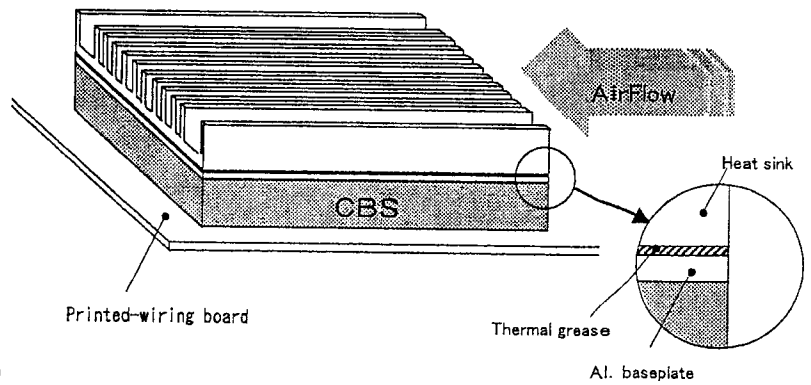

Fig.3 Test method

Note: Verify that baseplate temperature is below design level.

CBS2004815 Derating with Heat Sink (H=1.0inch)

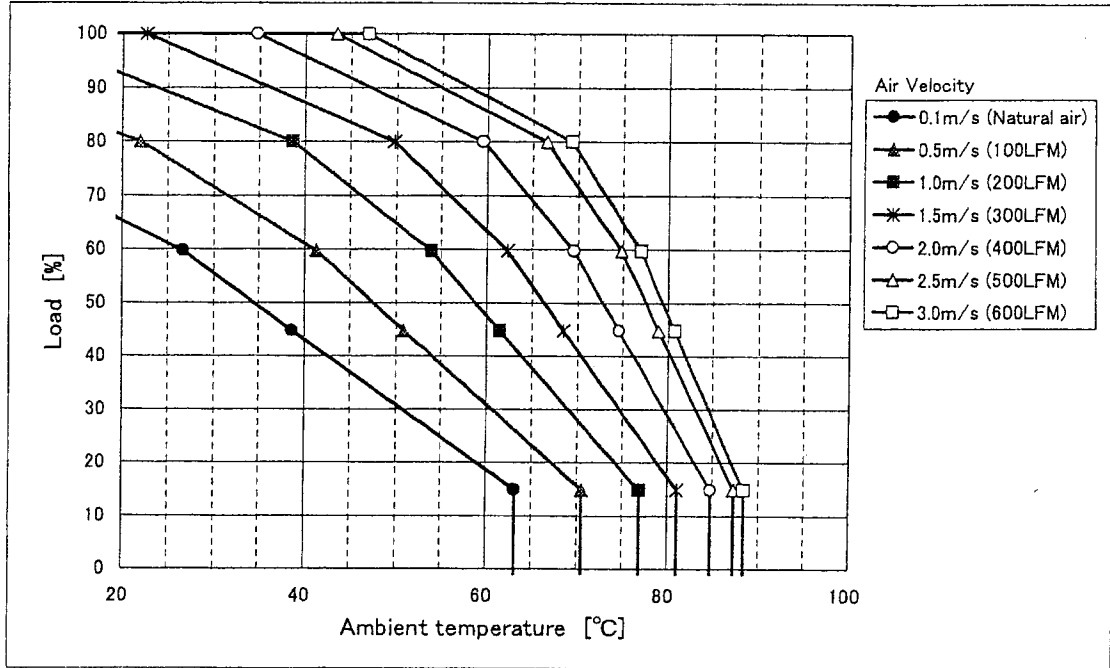

Fig. 1 CBS2004815 Derating (H=1.0inch)

※ 1 m/sec ≙ 200 LFM (linear feet per minute)

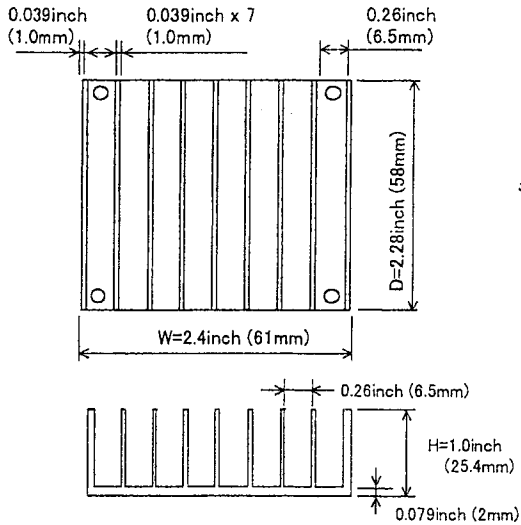

Fig.2 Size of Heat Sink

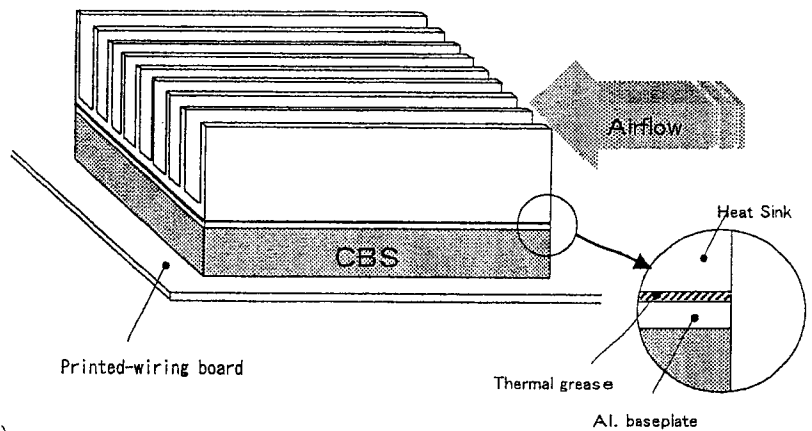

Fig.3 Test method

Note: Verify that baseplate temperature is below design level.

CBS2004815 Derating with Heat Sink (H=1.5inch)

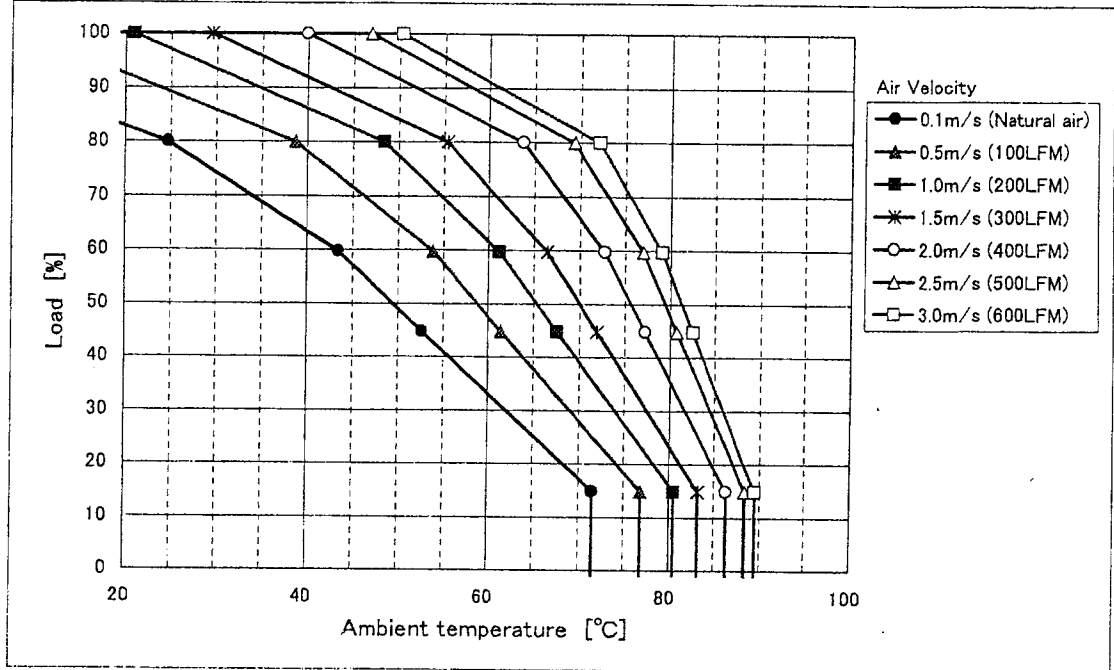

Fig. 1 CBS2004815 Derating (H=1.5inch)

※ 1 m/sec ≅ 200 LFM (linear feet per minute)

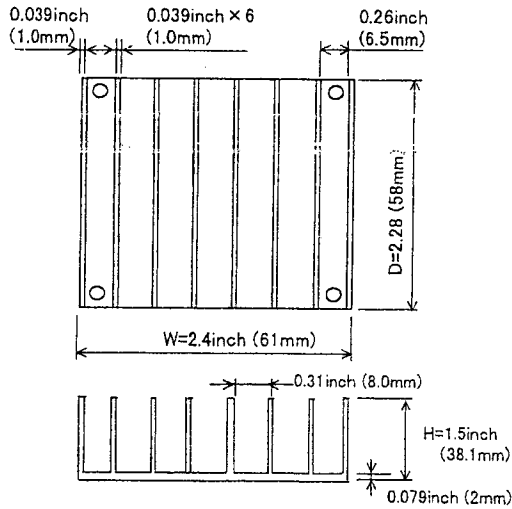

Fig.2 Size of Heat Sink

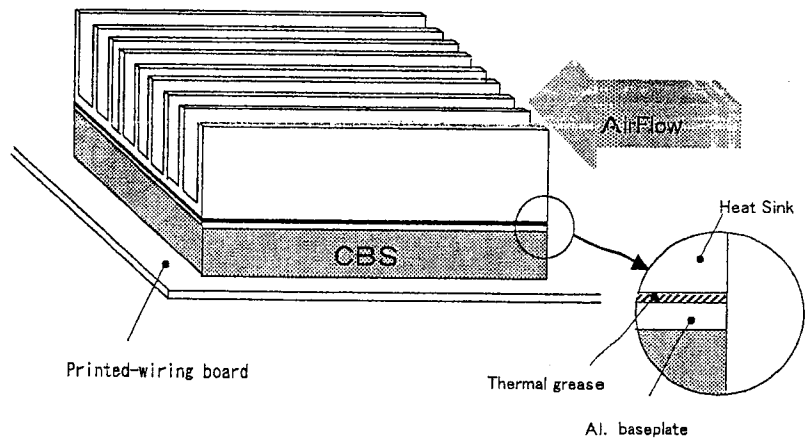

Fig.3 Test method

Note: Verify that baseplate temperature is below design level.